



# WALRUS®



## TQ Series

### Electronic Control Pump



## TQ SERIES Electronic Control Pumps



Power: 0.18 - 2.2 kW  
 Head: Up to 34M  
 Flow: Up to 250 L/min  
 Outlet: 1" - 2"

### Applications:

The TQ series pumps are designed for water supply and pressure boosting in residential, commercial and light industrial applications where low or inadequate water pressure exists. It is suitable for boosting pressure from underground or surface water supplies.

### Operation Conditions:

1. Ambient temperature: Max. +40°C
2. Liquid temperature: +4°C ~ +40°C
3. System Pressure : Max. 8.5 kg/cm<sup>2</sup>
4. Relative humidity: Max. 85% (RH)
5. Under normal operation, it is not necessary to adjust the pressure unless the cut in pressure is higher than preset activation point (refer to specification).

### Product Features:

1. The TQ is a complete, all-in-one unit, consisting of pump, motor, pressure tank, and electronic controller. The built-in electronic controller provides constant pressure which ensures that the pump starts automatically when water is consumed and operates continuously until water is not required.
2. Compact design and quiet operation make the TQ series suitable for many applications.
3. The TQ is constructed from the top quality corrosion resistant materials.
4. Pump has built in dry-run shut off with automatic reset function.
5. The motor has built-in thermal overload to protect against high operating temperatures and over current. (Single phase motor only)
6. The TQ has an anti-cycling feature which prevents the pump from continuous starting and stopping when you have a dripping tap or minor leak in the system.
7. The pumps will lift water up to 7.6m. with foot valve and pump suction piping filled with water.

### Dimensions:

#### TQ200/400/800

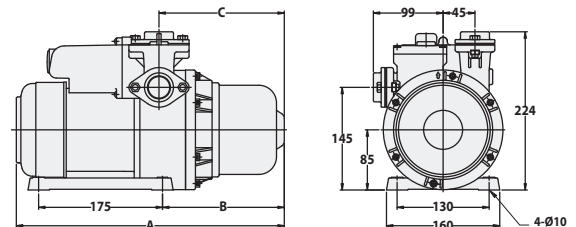

#### TQ1500/2200/3700

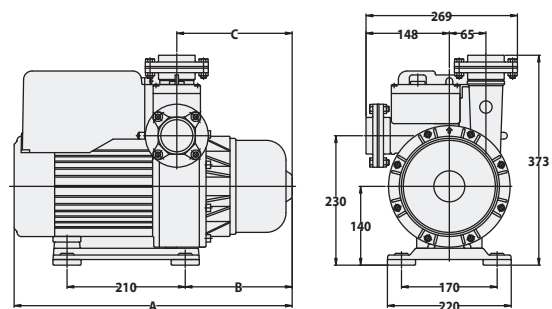

Model	Dimensions (mm)		
	A	B	C
TQ200	389	183	188
TQ400	405	198	203
TQ800	451	198	203
TQ1500	501	197	212
TQ2200	501	197	212

Performance curve:

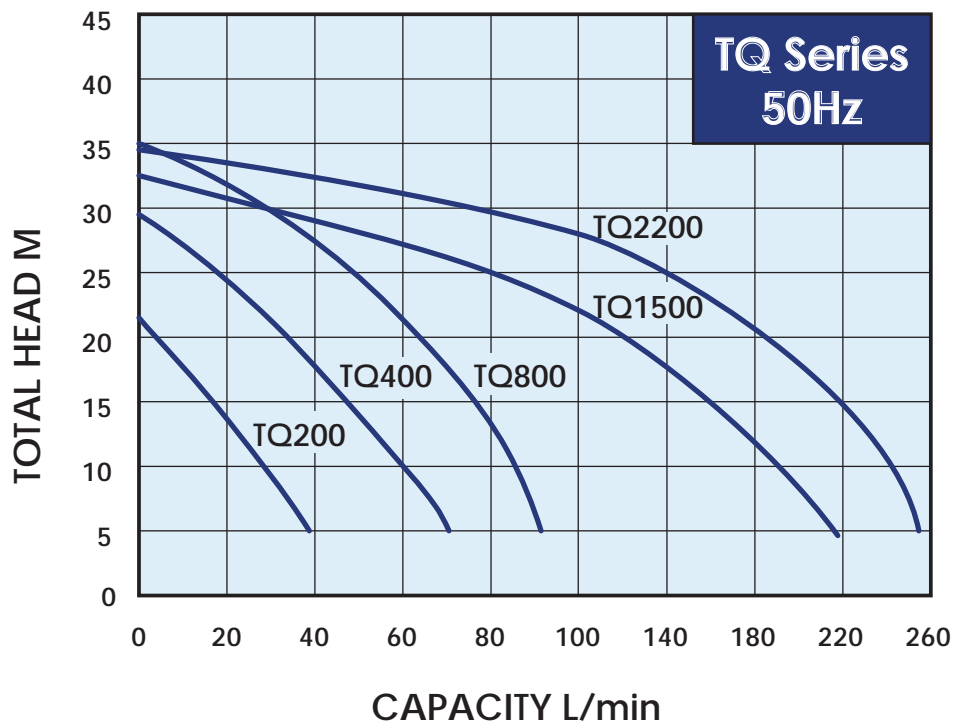

Specification:

Model	Power (kW)	Cycle (Hz)	Phase (Ø)	Voltage (V)	Amp's (A)	Inlet (in.)	Outlet (in.)	Preset activation point (kg/cm <sup>2</sup> )	H max. (m)	Q max. (L/min)	N.W. kg	
TQ200	0.18	50	1	200~240	1.5	1"	1"	1.2	22	45	7.4	30
TQ400	0.37	50	1	200~240	3	1"	1"	1.8	30	75	9.4	30
TQ800	0.75	50	1	200~240	4.4	1"	1"	2.0	35	95	11	24
TQ1500	1.5	50	1	200~240	7.2	2"	2"	2.5	32	230	29	12
			3	200~240	5.8							
			3	380~440	3.3							
TQ2200	2.2	50	1	200~240	11.1	2"	2"	2.5	34	250	31	12
			3	200~240	7.2							
			3	380~440	4.1							

**TQ SERIES**



**WALRUS®**

**WALRUS PUMP**